

SGP13010GE2D107

Cisco® Compatible 100/1000Base-LX SFP Transceiver (SMF, 1310nm, 10km, LC, DOM, -40 to 85C, SGMII)

Product Description

This Cisco® SFP transceiver provides 100/1000Base-LX throughput up to 10km over single-mode fiber (SMF) using a wavelength of 1310nm via an LC connector. It is guaranteed to be 100% compatible with the equivalent Cisco® transceiver. This easy to install, hot swappable transceiver has been programmed, uniquely serialized and data-traffic and application tested to ensure that it will initialize and perform identically. Digital optical monitoring (DOM) support is also present to allow access to real-time operating parameters. This transceiver is Trade Agreements Act (TAA) compliant. We stand behind the quality of our products and proudly offer a limited lifetime warranty.

Skylane's transceivers are RoHS compliant and lead-free.

Features:

- Built-In PHY Supporting SGMII Interface
- Dual-Rate of 100Base-LX/1000Base-LX Operation
- Built-In High Performance MCU Supporting Easier Configuration
- Up to 10km Transmission with SMF
- Standard Serial ID Information Compatible with SFP MSA
- 1310nm FP Laser and PIN Photo-Detector
- 3.3V Single Power Supply
- Duplex LC Connector
- RoHS Compliant and Lead-Free
- Operating Temperature: -40 to 85 Celsius



Applications:

- 1000Base-LX Ethernet
- Access and Enterprise
- 1x Fibre Channel

For your product safety, please read the following information carefully before any manipulation of the transceiver:



ESD

This transceiver is specified as ESD threshold 1kV for SFI pins and 2kV for all others electrical input pins, tested per MIL-STD-883G, Method 3015.4 / JESD22-A114-A (HBM). However, normal ESD precautions are still required during the handling of this module.



LASER SAFETY

This is a Class1 Laser Product according to IEC 60825-1:2007. This product complies with 21 CFR 1040.10 and 1040.11 except for deviations pursuant to Laser Notice No. 50, dated (June 24, 2007).

The optical ports of the module need to be terminated with an optical connector or with a dust plug in order to avoid contamination.

Absolute Maximum Ratings

Parameter	Symbol	Min.	Typ.	Max.	Unit	Notes
Supply Voltage	V _{cc}	-0.5		3.6	V	
Storage Temperature	T _{stg}	-40		85	°C	
Operating Case Temperature	T _c	-40		85	°C	
Relative Humidity	RH	5		95	%	
Data Rate	1000Base		1250		Mbps	
	100Base		125			

Electrical Characteristics

Parameter	Symbol	Min.	Typ.	Max.	Unit	Notes
Power Supply Voltage	V _{cc}	3.13	3.3	3.47		
Power Supply Current	I _{cc}			350	mA	1
Power Dissipation	P _{DISS}			1.5	W	
Transmitter						
Differential Data Input Swing	V _{IN}	500		2400	mV	2
Input Differential Impedance	Z _{IN}	80	100	120	Ω	
Tx_Disable	Disable		2.0	V _{cc}		
	Enable		V _{ee}	V _{ee} +0.8		
Tx_Fault	Fault		2.0	V _{cc}		
	Normal		V _{ee}	V _{ee} +0.5		
Receiver						
Differential Data Output Swing	V _{OUT}	370		2000	mV	2
LOS	High		2.0	V _{cc} +0.3	V	
	Low			V _{ee} +0.5		

Notes:

1. The maximum power supply current after the module is work stable.
2. PECL logic. Internally AC coupled.

Optical Characteristics

Parameter	Symbol	Min.	Typ.	Max.	Unit	Notes	
Transmitter							
Center Wavelength	λ_C	1260	1310	1360	nm		
Average Output Power	1000Base	POUT	-9.5		-3	dBm	1
	100Base	POUT	-15		-8		1
POUT @Tx_Disable Asserted	POUT				-45	dBm	1
Spectral Width (RMS)	1000Base	σ			4	nm	
	100Base				7.7		
Extinction Ratio	ER	9			dB		
Rise/Fall Time (20-80%)	1000Base	T_r/T_f			0.26	ns	2
	100Base				3		
Total Jitter Rate TP2	1000Base	JT			0.481	UI	3
	100Base				0.4		
Deterministic Jitter at TP2	1000Base	JD			0.250	UI	3
	100Base				0.305		
Output Optical Eye	Compatible with IEEE 802.3ah-2004						4
Receiver							
Center Wavelength	λ_C	1260	1310	1570	nm		
Receiver Sensitivity	1000Base				-22	dBm	5
	100Base				-28		6
Receiver Overload	1000Base				-3	dBm	5
	100Base				-8		6
Return Loss		12			dB		
LOS De-Assert	1000Base	LOSD				dBm	
	100Base						-23
LOS Assert	1000Base	LOSA				dBm	
	100Base						-45
LOS Hysteresis		0.5			4.5	dB	
Total Jitter at TP4 (SGMII)	JT				0.749	UI	3
Deterministic at TP4 (SGMII)	JD				0.462	UI	

Notes:

1. The optical power is launched into 9/125 μ m SMF.
2. Unfiltered, measured with 8B/10B code for 1.25Gbps and 4B/5B code for 125Mbps.
3. Meets the specified maximum output jitter requirements if the specified maximum input jitter is present.
4. Measured with 8B/10B code for 1.25Gbps and 4B/5B code for 125Mbps.
5. Measured with 8B/10B code for 1.25Gbps, worst-case extinction ratio, and $BER \leq 1 \times 10^{-12}$.
6. Measured with 4B/5B code for 125Mbps, worst-case extinction ratio, and $BER \leq 1 \times 10^{-12}$.

Pin Descriptions

Pin	Symbol	Name/Description	Plug Seq.	Notes
1	VeeT	Transmitter Ground.	1	
2	Tx_Fault	Transmitter Fault Indication.	3	1
3	Tx_Disable	Transmitter Disable.	3	2
4	MOD-DEF2	Module Definition 2.	3	3
5	MOD-DEF1	Module Definition 1.	3	3
6	MOD-DEF0	Module Definition 0.	3	3
7	Rate Select	Not Used.	3	
8	LOS	Loss of Signal.	3	4
9	VeeR	Receiver Ground.	1	
10	VeeR	Receiver Ground.	1	
11	VeeR	Receiver Ground.	1	
12	RD-	Inverse Received Data Out.	3	5
13	RD+	Received Data Out.	3	5
14	VeeR	Receiver Ground.	1	
15	VccR	Receiver Power.	2	
16	VccT	Transmitter Power.	2	
17	VeeT	Transmitter Ground.	1	
18	TD+	Transmit Data In.	3	6
19	TD-	Inverse Transmit Data In.	3	6
20	VeeT	Transmitter Ground.	1	

Notes:

- Tx_Fault is an open collector output, which should be pulled up with a 4.7kΩ to 10kΩ resistor on the host board to a voltage between 2.0V and Vcc+0.3V. “Logic 0” indicates normal operation. “Logic 1” indicates a laser fault of some kind. In the “low” state, the output will be pulled to <0.8V.
- Tx_Disable is an input that is used to shut down the transmitter optical output. It is pulled up within the module with a 4.7kΩ to 10kΩ resistor. Its states are:
 - Low (0V to 0.8V): Transmitter On
 - (>0.8V and <2V): Undefined
 - High (2.0V to 3.465V): Transmitter Disabled
 - Open: Transmitter Disabled.
- MOD-DEF0, 1, & 2. These are the module definition pins. They should be pulled up with a 4.7kΩ to 10kΩ resistor on the host board. The pull-up voltage shall be VccT or VccR.
 - MOD-DEF0 is grounded by the module to indicate that the module is present.
 - MOD-DEF1 is the clock line of 2-wire serial interface for optional serial ID.
 - MOD-DEF2 is the data line of 2-wire serial interface for optional serial ID.

4. LOS (Loss of Signal) is an open collector/drain output, which should be pulled up with a 4.7kΩ to 10kΩ resistor on the host board to a voltage between 2.0V and Vcc+0.3V. “Logic 0” indicates normal operation. “Logic 1” indicates loss of signal or link down with partner I. In the “low” state, the output will be pulled to less than 0.8V.
5. These are the differential receiver outputs. They are internally AC coupled 100Ω differential lines which should be terminated with 100Ω (differential) at host with SGMII interface.
6. These are the differential transmitter inputs. They are AC coupled, differential lines with 100Ω differential termination inside the module.

Pin Definitions

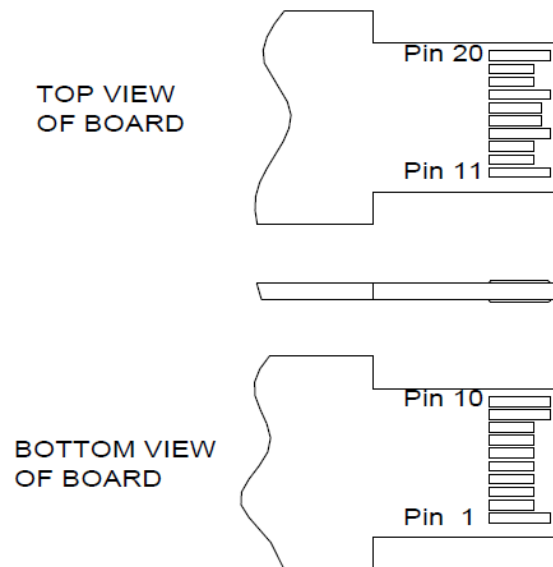

Recommended Host Board Power Supply Circuit

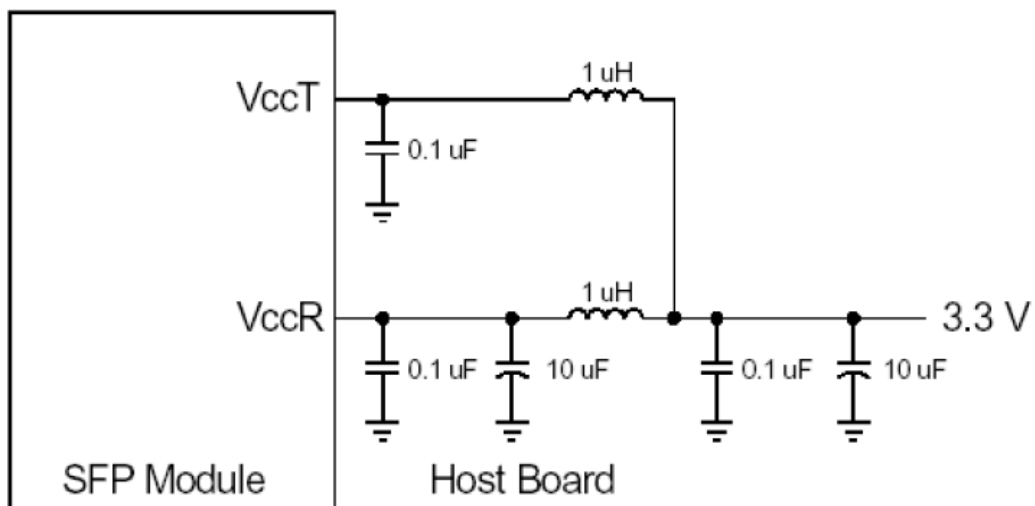

Recommended Interface Circuit

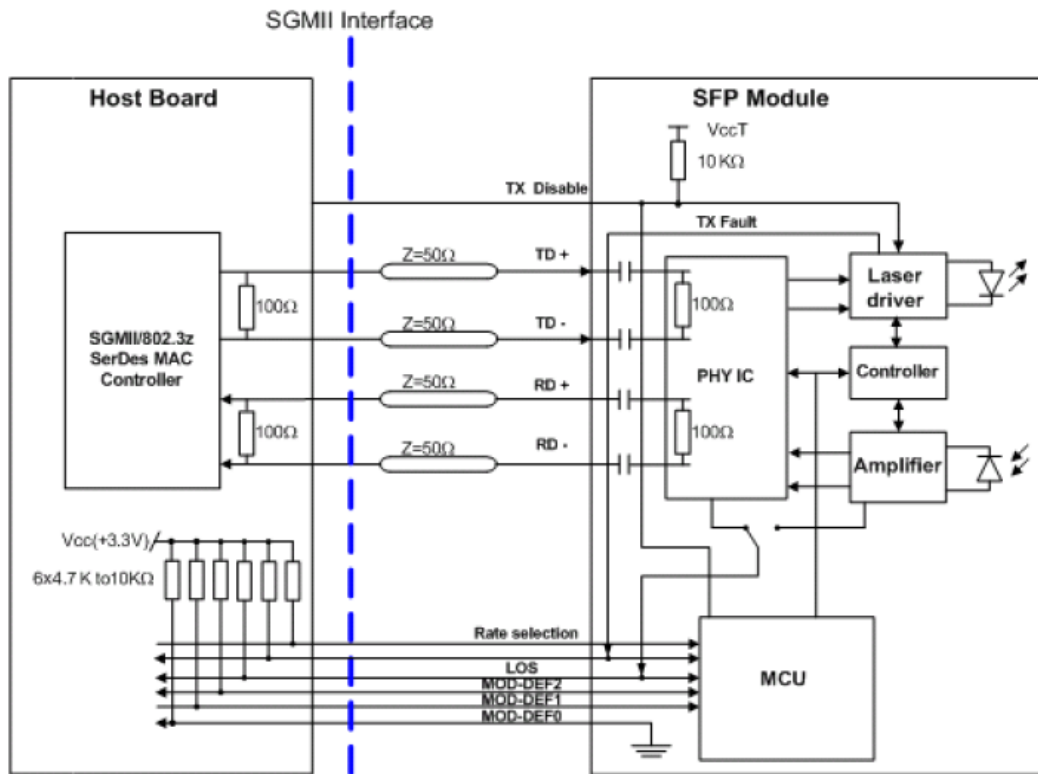

Mechanical Specifications

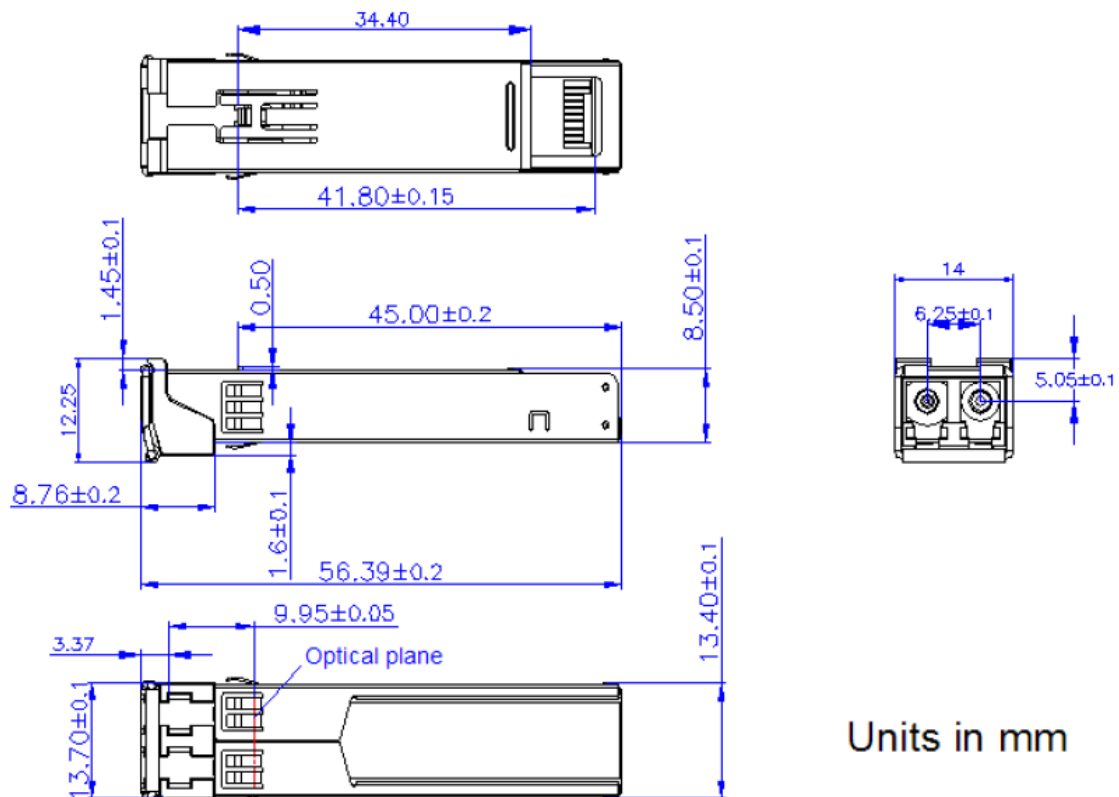

Units in mm

About Skylane Optics

Skylane is a leading provider of transceivers for optical communication.

We offer an extensive portfolio for the enterprise, access, datacenter and metropolitan fiber optical market as well as for smart home applications and home networks.

We cover the European, South American and North American market with a strong partner network and have offices in Belgium, Brazil, Sweden and USA.

Our offerings are characterized by high quality and performance. In combination with our strong technical support, we enable our customers to build cost optimized network solutions.

We offer an extensive range of high-quality products including transceivers (Optical and copper), Active Optical Cable (AOC), Direct Attach Cable (DAC), Mux/Demux, Coding Box.

