



Q28QD040C15D000

MSA and TAA OTU-4-ER4 100GbE Dual-Rate QSFP28 Transceiver (SMF, 1295nm to 1309nm, 40km, LC, DOM)

Product Description

This MSA Compliant QSFP28-OTU4-ER4 compatible QSFP28 transceiver provides 100GBase/OTU4-ER4 throughput up to 40km over single-mode fiber (SMF) using a wavelength of 1295nm to 1309nm via an LC connector. It is built to MSA standards and is uniquely serialized and data-traffic and application tested to ensure that they will integrate into your network seamlessly. Digital optical monitoring (DOM) support is also present to allow access to real-time operating parameters. This transceiver is Trade Agreements Act (TAA) compliant. We stand behind the quality of our products and proudly offer a limited lifetime warranty.

Skylane's transceivers are RoHS compliant and lead-free.

Features:

- SFF-8665 Compliance
- Duplex LC Connector
- Commercial Temperature 0 to 70 Celsius
- Single-mode Fiber
- Hot Pluggable
- Excellent ESD Protection
- Metal with Lower EMI
- RoHS Compliant and Lead Free



Applications:

- 100GBase Ethernet
- Access and Enterprise
- OTN OTU4

For your product safety, please read the following information carefully before any manipulation of the transceiver:



ESD

This transceiver is specified as ESD threshold 1kV for SFI pins and 2kV for all others electrical input pins, tested per MIL-STD-883G, Method 3015.4 / JESD22-A114-A (HBM). However, normal ESD precautions are still required during the handling of this module.



LASER SAFETY

This is a Class1 Laser Product according to IEC 60825-1:2007. This product complies with 21 CFR 1040.10 and 1040.11 except for deviations pursuant to Laser Notice No. 50, dated (June 24, 2007).

The optical ports of the module need to be terminated with an optical connector or with a dust plug in order to avoid contamination.

Regulatory Compliance

- ESD to the Electrical PINs: compatible with MIL-STD-883E Method 3015.4
- ESD to the LC Receptacle: compatible with IEC 61000-4-3
- EMI/EMC compatible with FCC Part 15 Subpart B Rules, EN55022:2010
- Laser Eye Safety compatible with FDA 21CFR, EN60950-1& EN (IEC) 60825-1,2
- RoHS compliant with EU RoHS 2.0 directive 2015/863/EU

Absolute Maximum Ratings

Parameter	Symbol	Min.	Typ.	Max.	Unit
Maximum Supply Voltage	V _{cc}	0		3.6	V
Storage Temperature	T _s	-40		85	°C
Operating Case Temperature	T _{op}	0		70	°C
Relative Humidity	RH	5		85	%
Damage Threshold, each lane	THd	5.5			dBm
Link Distance with G.652				40	km

Electrical Characteristics

Parameter	Symbol	Min	Typ	Max	Unit	Notes
Supply Voltage	Vcc	3.135	3.3	3.465	V	
Power dissipation				5	W	
Supply Current	Icc			1.4430	A	Steady state
Transmitter						
Data Rate, each lane			25.78125		Gbps	1
			27.9525		Gbps	2
Differential Voltage pk-pk	Vpp			900	mV	At 1 MHz
Common Mode Voltage	Vcm	-350		2850	mV	
Transition time	Trise/Tfall	10			ps	20%~80%
Differential Termination Resistance Mismatch				10	%	
Eye width	EW15	0.46			UI	
Eye height	EH15	95			mV	
Receiver						
Data Rate, each lane			25.78125		Gbps	1
			27.9525		Gbps	2
Differential Termination Resistance Mismatch				10	%	At 1 MHz
Differential output voltage swing	Vout, pp			900	mV	
Common Mode Noise, RMS	Vrms			17.5	mV	
Transition time	Trise/Tfall	12			ps	20%~80%
Eye width	EW15	0.57			UI	
Eye height	EH15	228			mV	

Notes:

1. For use of 100GBASE-ER4.
2. For use of OTU4.

Optical Characteristics

100GBASE-ER4 Operation (EOL, TOP = 0 to +70 °C , VCC = 3.135 to 3.465 Volts)

Parameter	Symbol	Min	Typical	Max	Unit	Notes
Transmitter						
Signaling Speed per Lane		25.78125 ± 100 ppm			Gb/s	
Transmit wavelengths	L1	1294.53		1296.59	nm	
	L2	1299.02		1301.09	nm	
	L3	1303.54		1305.63	nm	
	L4	1308.09		1310.19	nm	
Total Average Launch Power	Po			8.9	dBm	
Average launch power, each lane	Po	-2.9		2.9	dBm	
Optical Modulation Amplitude (OMA), each lane	OMA	0.1		4.5	dBm	
Difference in launch power between any two lanes(Average and OMA)				3.6	dB	
Transmitter and Dispersion Penalty (TDP), each lane	TDP			2.5	dB	
Extinction Ratio	ER	8			dB	
RIN _{20OMA}				-130	dB/Hz	
Side Mode Suppression Ratio	SMSR	30			dB	
Optical Return Loss Tolerance	ORLT			20	dB	
Transmitter reflectance				-12	dB	
Transmitter eye mask definition {X1, X2, X3, Y1, Y2, Y3}		{0.25, 0.4, 0.45, 0.25, 0.28, 0.4}				1
Mask margin		5			%	1
Receiver						
Signaling Speed per Lane		25.78125 ±100 ppm			Gb/s	
Receive wavelengths	L1	1294.53		1296.59	nm	
	L2	1299.02		1301.09	nm	
	L3	1303.54		1305.63	nm	
	L4	1308.09		1310.19	nm	
Damage threshold, each lane	P _{damage}	5.5			dBm	
Average receiver power, each lane		-20.9		-3.5	dBm	
Receiver power, each lane(OMA)				-3.5	dBm	
Receiver Reflectance	R _f			-26	dB	
Receiver sensitivity (AOP), each lane	S			-20.9	dBm	2
Receiver 3 dB electrical upper cutoff frequency, each lane				31	GHz	
LOS Assert	LOSA	-33			dBm	

LOS Deassert	LOSD			-22	dBm	
LOS Hysteresis	LOSH	0.5			dB	

Notes:

1. Hit ratio 5×10^{-5} .
2. Sensitivity is specified at BER@1E-12 without FEC.

Optical Characteristics

OTU4 Operation (EOL, TOP = 0 to +70 °C , VCC = 3.135 to 3.465 Volts)

Parameter	Symbol	Min	Typical	Max	Unit	Notes
Transmitter						
Signaling Speed per Lane		27.9525 ± 20 ppm			Gb/s	
Transmit wavelengths	L1	1294.53		1296.59	nm	
	L2	1299.02		1301.09	nm	
	L3	1303.54		1305.63	nm	
	L4	1308.09		1310.19	nm	
Total Average Launch Power	Po			8.9	dBm	
Average launch power, each lane	Po	-2.7		2.9	dBm	
Difference in launch power between any two lanes (Average and OMA)				3.6	dB	
Extinction Ratio	ER	8			dB	
Optical Return Loss Tolerance	ORLT			20	dB	
Transmitter reflectance				-26	dB	
Transmitter eye mask definition {X1, X2, X3, Y1, Y2, Y3}		{0.25, 0.4, 0.45, 0.25, 0.28, 0.4}				1
Mask margin		5			%	1
Receiver						
Signaling Speed per Lane		27.9525 ± 20 ppm			Gb/s	
Receive wavelengths	L1	1294.53		1296.59	nm	
	L2	1299.02		1301.09	nm	
	L3	1303.54		1305.63	nm	
	L4	1308.09		1310.19	nm	
Average receiver power, each lane		-20.7		-3.5	dBm	
Receiver power, each lane(OMA)				-3.5	dBm	
Difference in receive power between any two lanes (Average and OMA)				4.5		
Receiver Reflectance	Rf			-26	dB	
Receiver sensitivity (AOP), each lane	S			-23.2	dBm	2

Receiver 3 dB electrical upper cutoff frequency, each lane				31	GHz	
LOS Assert	LOSA	-33			dBm	
LOS Deassert	LOSD			-24	dBm	
LOS Hysteresis	LOSH	0.5			dB	

Notes:

1. Hit ratio 5×10^{-5} .
2. Sensitivity is specified at BER@5E-5 with FEC.

Electrical Pin-out Details

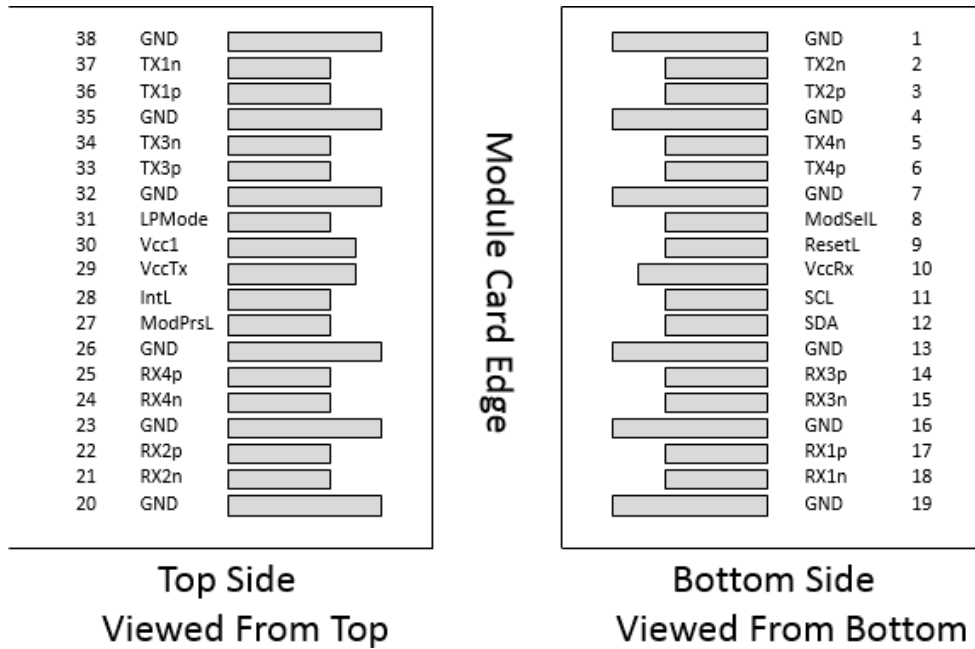

Pin Descriptions

Pin	Symbol	Name/Descriptions	Ref.
1	GND	Ground	1
2	Tx2n	Transmitter Inverted Data Input	
3	Tx2p	Transmitter Non-Inverted Data Input	
4	GND	Ground	1
5	Tx4n	Transmitter Inverted Data Input	
6	Tx4p	Transmitter Non-Inverted Data Input	
7	GND	Ground	1
8	ModSelL	Module Select	
9	ResetL	Module Reset	
10	Vcc Rx	+3.3V Power Supply Receiver	
11	SCL	2-wire serial interface clock	
12	SDA	2-wire serial interface data	
13	GND	Ground	1
14	Rx3p	Receiver Non-Inverted Data Output	
15	Rx3n	Receiver Inverted Data Output	
16	GND	Ground	1
17	Rx1p	Receiver Non-Inverted Data Output	
18	Rx1n	Receiver Inverted Data Output	
19	GND	Ground	1
20	GND	Ground	1
21	Rx2n	Receiver Inverted Data Output	
22	Rx2p	Receiver Non-Inverted Data Output	
23	GND	Ground	1
24	Rx4n	Receiver Non-Inverted Data Output	
25	Rx4p	Receiver Inverted Data Output	
26	GND	Ground	1
27	ModPrsL	Module Present	
28	IntL	Interrupt	
29	Vcc Tx	+3.3V Power supply transmitter	
30	Vcc1	+3.3V Power supply	
31	LPMode	Low Power Mode	
32	GND	Ground	1
33	Tx3p	Transmitter Non-Inverted Data Input	
34	Tx3n	Transmitter Inverted Data Input	
35	GND	Ground	1
36	Tx1p	Transmitter Non-Inverted Data Input	
37	Tx1n	Transmitter Inverted Data Input	
38	GND	Ground	1

Notes:

1. Circuit ground is internally isolated from chassis ground.

Recommended Host Board Power Supply Filter Network

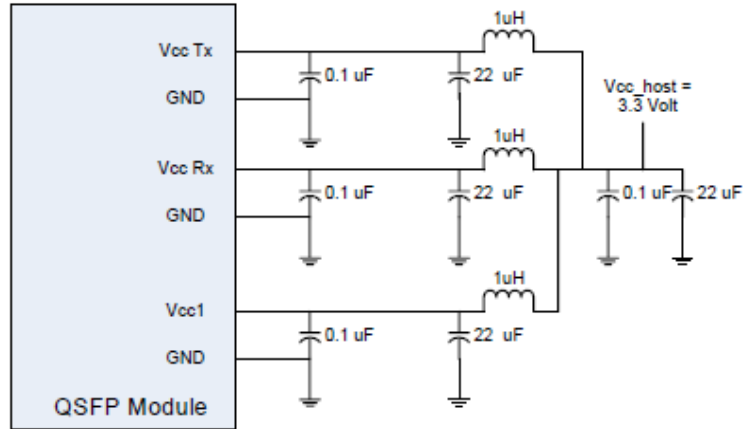

Transceiver Block Diagram

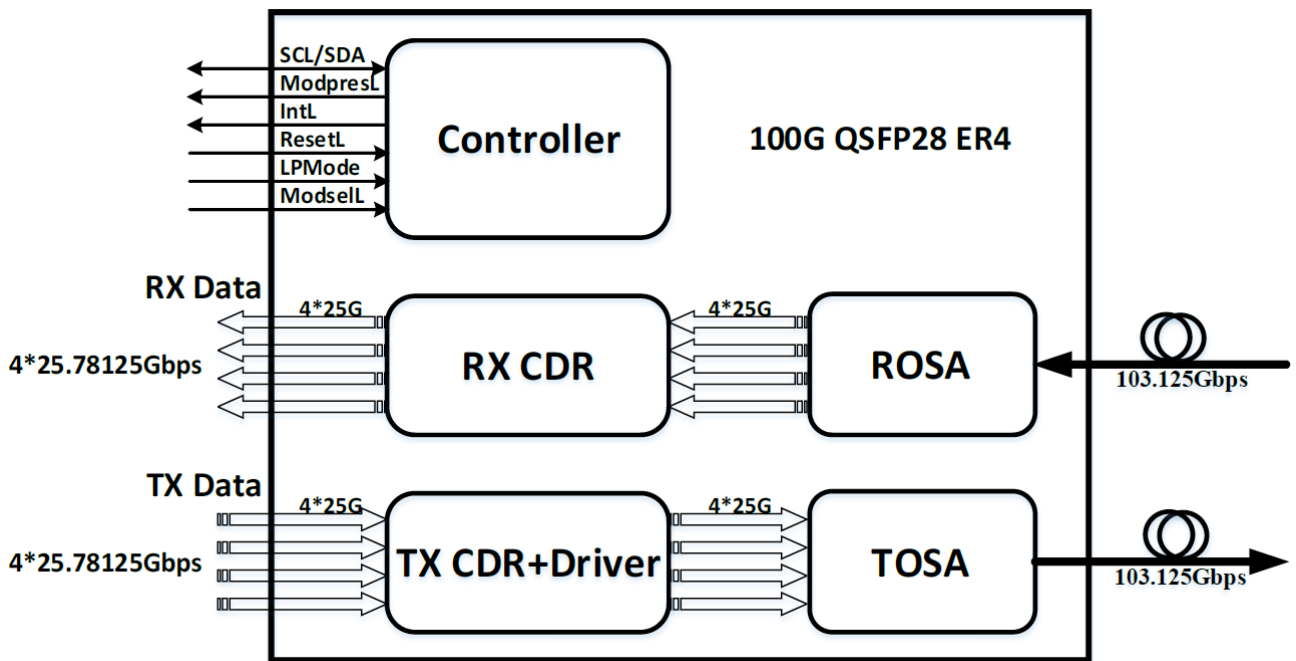

Mechanical Specifications

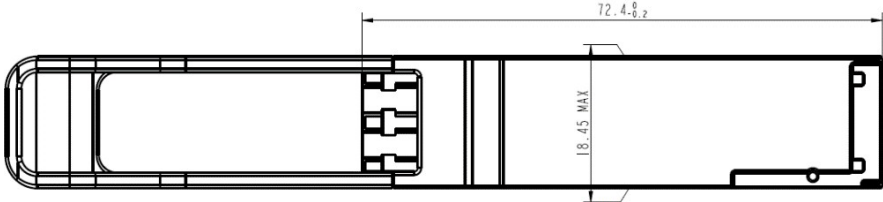
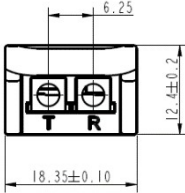
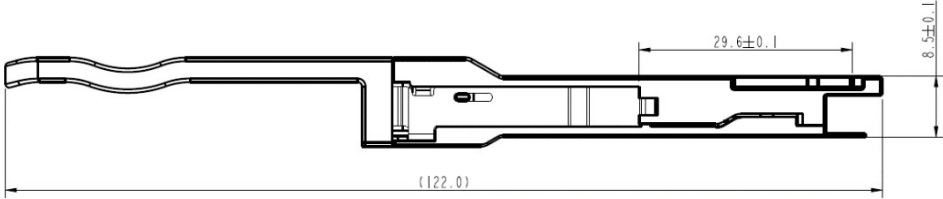
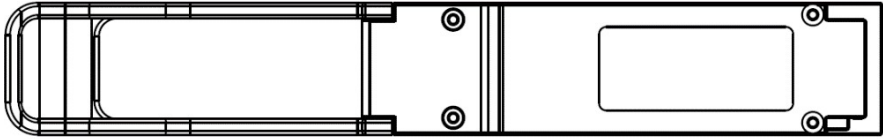

About Skylane Optics

Skylane is a leading provider of transceivers for optical communication.

We offer an extensive portfolio for the enterprise, access, datacenter and metropolitan fiber optical market as well as for smart home applications and home networks.

We cover the European, South American and North American market with a strong partner network and have offices in Belgium, Brazil, Sweden and USA.

Our offerings are characterized by high quality and performance. In combination with our strong technical support, we enable our customers to build cost optimized network solutions.

We offer an extensive range of high-quality products including transceivers (Optical and copper), Active Optical Cable (AOC), Direct Attach Cable (DAC), Mux/Demux, Coding Box.

