



Q28QD080C08F000

MSA and TAA 100GBase-ZR4 QSFP28 Transceiver (SMF, 1295nm to 1309nm, 80km, LC, DOM, -40 to 85C)

Product Description

This MSA Compliant QSFP28 transceiver provides 100GBase-ZR4 throughput up to 80km over single-mode fiber (SMF) using a wavelength of 1295nm to 1309nm via an LC connector. It is built to MSA standards and is uniquely serialized and data-traffic and application tested to ensure that they will integrate into your network seamlessly. Digital optical monitoring (DOM) support is also present to allow access to real-time operating parameters. This transceiver is Trade Agreements Act (TAA) compliant. We stand behind the quality of our products and proudly offer a limited lifetime warranty.

Skylane's transceivers are RoHS compliant and lead-free.

Features:

- QSFP28 MSA Compliant
- 4 LAN-WDM Lanes MUX/DEMUX Design
- Supports 103.125Gbps Aggregate Bit Rate
- EML Laser and PIN+SOA Receiver
- Single 3.3V Power Supply
- 4x25G Electrical Interface
- Duplex LC Connector
- Maximum Power Consumption of 6.5W
- Single-Mode Fiber
- Industrial Temperature: -40 to 85 Celsius
- Hot Pluggable
- RoHS Compliant and Lead-Free



Applications:

- 100GBase Ethernet
- Access and Enterprise

For your product safety, please read the following information carefully before any manipulation of the transceiver:



ESD

This transceiver is specified as ESD threshold 1kV for SFI pins and 2kV for all others electrical input pins, tested per MIL-STD-883G, Method 3015.4 /JESD22-A114-A (HBM). However, normal ESD precautions are still required during the handling of this module.



LASER SAFETY

This is a Class1 Laser Product according to IEC 60825-1:2007. This product complies with 21 CFR 1040.10 and 1040.11 except for deviations pursuant to Laser Notice No. 50, dated (June 24, 2007).

The optical ports of the module need to be terminated with an optical connector or with a dust plug in order to avoid contamination.

Absolute Maximum Ratings

Parameter	Symbol	Min.	Max.	Unit	Notes
Maximum Supply Voltage	Vcc	0	3.6	V	
Storage Temperature	Tstg	-40	85	°C	
Operating Case Temperature	Tc	-40	85	°C	1
Operating Humidity	RH	0	85	%	

Notes:

1. Industrial temperature range.

Electrical Characteristics

Parameter	Symbol	Min.	Typ.	Max.	Unit	Notes
Power Supply Voltage	Vcc	3.13	3.30	3.47	V	
Power Dissipation				6.5	W	
Transmitter						
Data Rate Per Lane			25.78125		Gbps	
Differential Voltage Pk-Pk	Vpp			900	mV	1
Common-Mode Voltage	Vcm	-350		2850	mV	
Transition Time	Tr/Tf	10			ps	2
Differential Termination Resistance Mismatch				10	%	
Eye Width	EW15	0.46			UI	
Eye Height	EH15	95			mV	
Receiver						
Data Rate Per Lane			25.78125		Gbps	
Differential Termination Resistance Mismatch				10	%	1
Differential Output Voltage Swing	VOUT,pp			900	mV	
Common-Mode Noise (RMS)	Vrms			17.5	mV	
Transition Time	Tr/Tf	12			ps	2
Eye Width	EW15	0.57			UI	
Eye Height	EH15	228			mV	

Notes:

1. At 1MHz.
2. 20-80%.

Optical Characteristics

Parameter	Symbol	Min.	Typ.	Max.	Unit	Notes
9/125µm G.652 SMF	Lmax			80	km	
Transmitter						
Signaling Speed Per Lane		25.78125±100ppm			Gbps	
Optical Wavelength	L0	1294.53		1296.59	nm	
	L1	1299.02		1301.09	nm	
	L2	1303.54		1305.63	nm	
	L3	1308.09		1310.19	nm	
Side-Mode Suppression Ratio	SMSR	30			dB	
Total Average Launch Power		8		12.5	dBm	
Average Launch Power Per Lane		2		6.5	dBm	
Difference in Launch Power Between Any Two Lanes (Average and OMA)				3	dBm	
Average Launch Power of Off Transmitter Per Lane				-30	dBm	
Extinction Ratio	ER	6			dB	
RIN OMA				-130	dB/Hz	
Optical Return Loss Tolerance	ORLT			20	dB	
Transmitter Reflectance				-12	dB	
Transmitter Eye Mask Definition: (X1, X2, X3, Y1, Y2, Y3)		(0.25, 0.4, 0.45, 0.25, 0.28, 0.4)				1
Mask Margin		5			%	
Receiver						
Signaling Speed Per Lane		25.78125±100ppm			Gbps	
Receive Wavelengths	L0	1294.53		1296.59	nm	
	L1	1299.02		1301.09	nm	
	L2	1303.54		1305.63	nm	
	L3	1308.09		1310.19	nm	
Average Receiver Power Per Lane		-28		-7	dBm	
Receiver Power Per Lane (OMA)				-7	dBm	
Receiver Reflectance				-26	dB	
Receiver Sensitivity Average Per Lane				-28	dBm	1
Receiver 3dB Electrical Upper Cutoff Frequency Per Lane				31	GHz	
Damage Threshold Per Lane		6.5			dBm	
LOS De-Assert	LOSD			-29	dBm	
LOS Assert	LOSA	-40			dBm	
LOS Hysteresis	LOSH	0.5			dB	

Notes:

1. Sensitivity is specified at BER@5E⁻⁵ with FEC.

Pin Descriptions

Pin	Symbol	Name/Description	Notes
1	GND	Module Ground.	1
2	Tx2-	Transmitter Inverted Data Input.	
3	Tx2+	Transmitter Non-Inverted Data Input.	
4	GND	Module Ground.	1
5	Tx4-	Transmitter Inverted Data Input.	
6	Tx4+	Transmitter Non-Inverted Data Input.	
7	GND	Module Ground.	1
8	ModSelL	Module Select.	
9	ResetL	Module Reset.	
10	VccRx	+3.3V Receiver Power Supply.	
11	SCL	2-Wire Serial Interface Clock.	
12	SDA	2-Wire Serial Interface Data.	
13	GND	Module Ground.	1
14	Rx3+	Receiver Non-Inverted Data Output.	
15	Rx3-	Receiver Inverted Data Output.	
16	GND	Module Ground.	1
17	Rx1+	Receiver Non-Inverted Data Output.	
18	Rx1-	Receiver Inverted Data Output.	
19	GND	Module Ground.	1
20	GND	Module Ground.	1
21	Rx2-	Receiver Inverted Data Output.	
22	Rx2+	Receiver Non-Inverted Data Output.	
23	GND	Module Ground.	1
24	Rx4-	Receiver Non-Inverted Data Output.	
25	Rx4+	Receiver Inverted Data Output.	
26	GND	Module Ground.	1
27	ModPrsL	Module Present.	
28	IntL	Interrupt.	
29	VccTx	+3.3V Transmitter Power Supply.	
30	Vcc1	+3.3V Power Supply.	
31	LPMODE	Low-Power Mode.	
32	GND	Module Ground.	1
33	Tx3+	Transmitter Non-Inverted Data Input.	
34	Tx3-	Transmitter Inverted Data Input.	
35	GND	Module Ground.	1

36	Tx1+	Transmitter Non-Inverted Data Input.	
37	Tx1-	Transmitter Inverted Data Input.	
38	GND	Module Ground.	1

Notes:

1. Circuit ground is internally isolated from the chassis ground.

Electrical Pad Layout

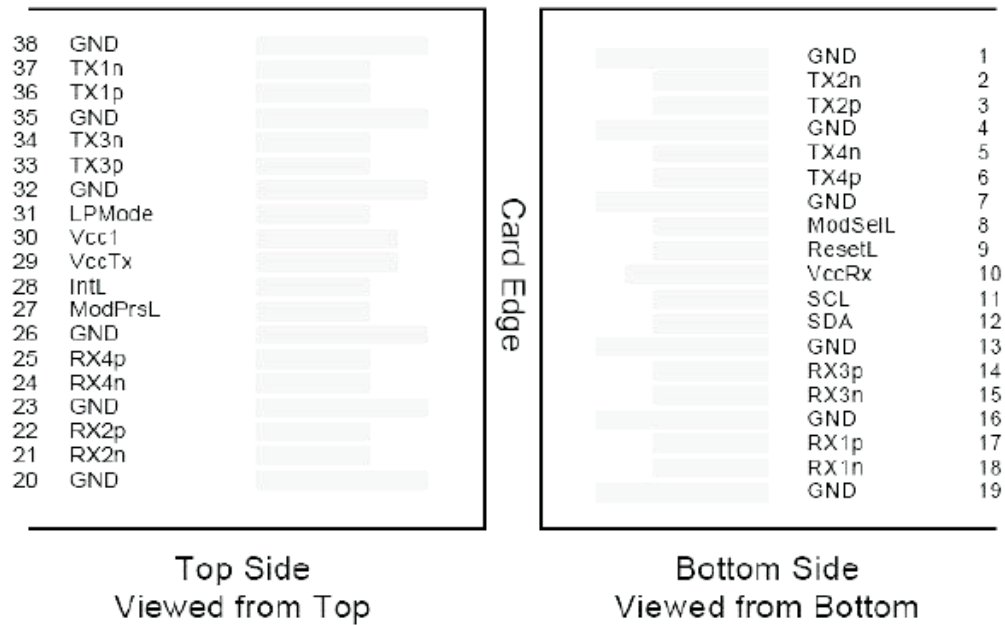

Pin-Out of Connector Block on the Host Board

Transceiver Block Diagram

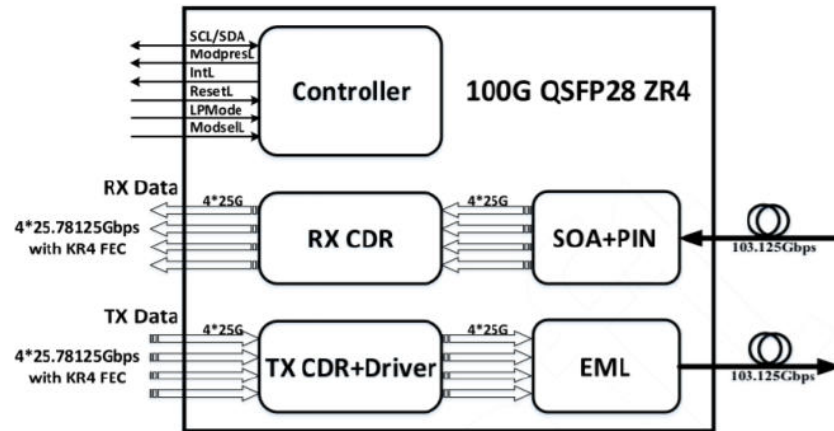

EEPROM Information

EEPROM memory map-specific data field description is as below:

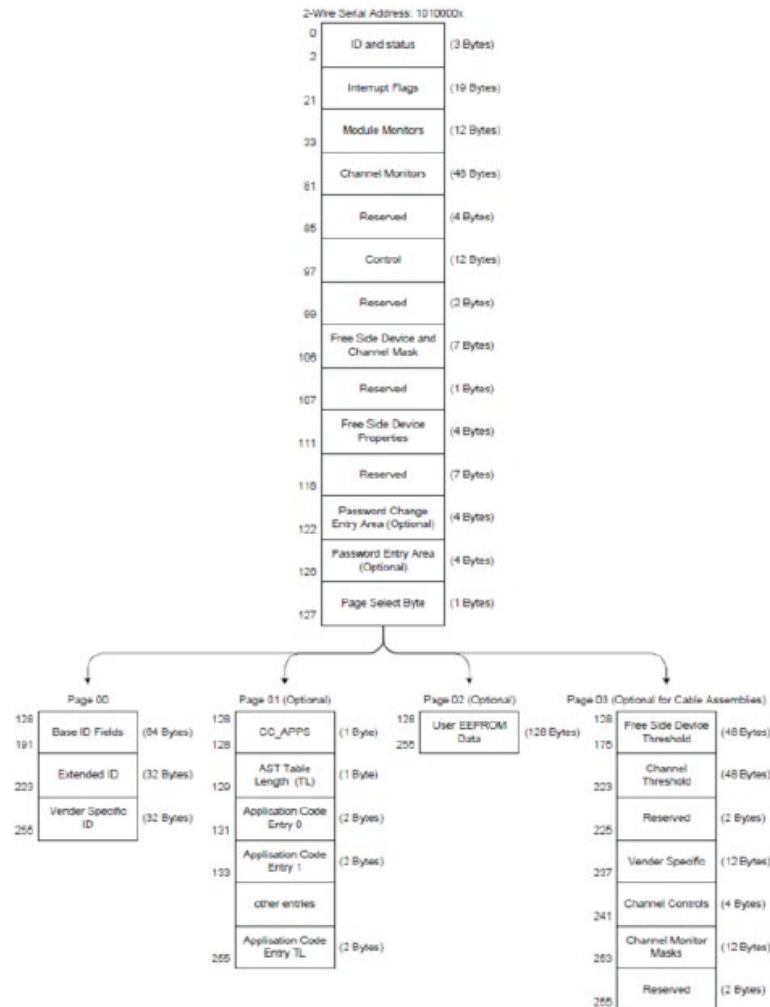

Digital Diagnostic Monitoring Interface

Parameter	Related Bytes (A0[00] Memory)	Accuracy	Notes
Temperature	22 to 23	$\pm 3^{\circ}\text{C}$	1, 2
Voltage	26 to 27	<3%	2
Bias Current	42 to 49	<10%	2
Tx Power	50 to 57	<3dB	2
Rx Power	34 to 41	<3dB	2

Notes:

1. Actual temperature test point is fixed on the module case around the laser.
2. Full operating temperature range.
3. Five transceiver parameter values are monitored. The table above defines the Monitory parameter's accuracy.

Mechanical Specifications

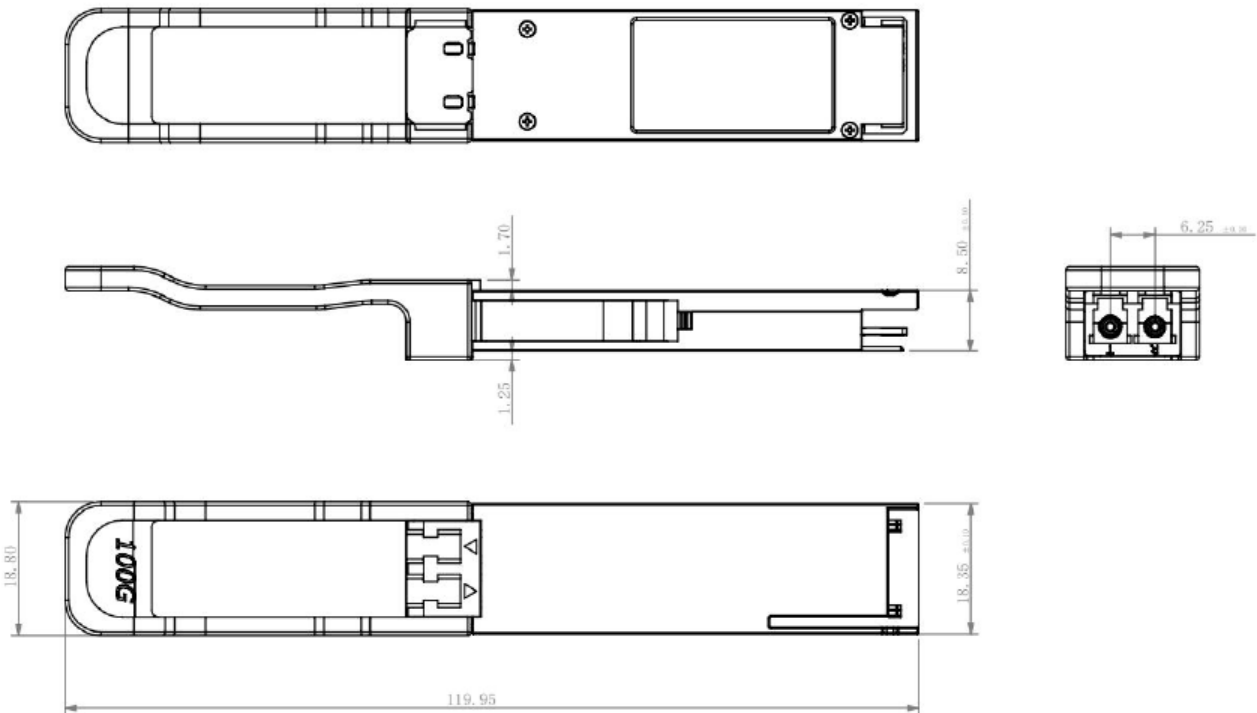

About Skylane Optics

Skylane is a leading provider of transceivers for optical communication.

We offer an extensive portfolio for the enterprise, access, datacenter and metropolitan fiber optical market as well as for smart home applications and home networks.

We cover the European, South American and North American market with a strong partner network and have offices in Belgium, Brazil, Sweden and USA.

Our offerings are characterized by high quality and performance. In combination with our strong technical support, we enable our customers to build cost optimized network solutions.

We offer an extensive range of high-quality products including transceivers (Optical and copper), Active Optical Cable (AOC), Direct Attach Cable (DAC), Mux/Demux, Coding Box.

